

Care of Kodak Carousel projectors (please read me first)

1. ALWAYS ENSURE THAT YOUR CAROUSEL MAGAZINES ARE IN GOOD CONDITION BEFORE PROCEEDING.

- *if the base plate of the mag looks bent or the teeth are damaged or missing do not use it.
- *if in doubt use a new one/or spare one if provided. Faulty slide magazines damage the projector mechanism which can be costly to repair.

ALWAYS CHECK THE SLIDES:

*Any damaged ,bent, cracked or half open, warped or distorted slides especially light weight/readimount slides, (which can easily bend after a few uses), will damage the projector mechanism.

*Always use good quality uniform slide mounts for the best results. We use [GEPE 24x36mm Glass Slide mounts 2.3 mm \(Type SB\)](#).

We recommend using good quality **uniform slidemounts** in any one show as this will eliminate the problem of some of the images being out of focus. Glass slide mounts also help the work stay in focus.

2. POSITIONING

- *Always ensure that the projector is mounted in a secure vibration free place with both legs and the base on the surface. if operating above head height ensure the projector is properly secured to the structure with a **safety bond** and will not slide off.
- *To ensure a "square" image, always mount the projector horizontally, perpendicular to the image area.
- *slides are gravity fed, so don't tilt the projector beyond @15degrees of horizontal or it will jam.
- *make sure nothing is resting on the magazine and that it has room to rotate freely.
- *If the public has access to or is able to touch the equipment, ensure that it is securely mounted and in the view of a responsible person at all times.

3. FITTING THE SLIDES

- *Place a slide in the zero slot of the projector (upside down, right way round)
- *Making sure the carousel magazine lid is securely attached in its locked position, turn the 80 slide magazine upside down.
- *Ensure the magazine is located with its location slot locked at < 0 > notch before placing it on the projector
- *if it is not at < 0 > rotate the base of the mag until it clicks into place.

4. POWERING UP

- *Plug in and switch on the projector at the rear switch
- *If the fan does not come on straight away, check that the mains power is live and switched on.
- *Check the kettle lead (IEC) is live and if necessary change the fuse.(3A or 5A is sufficient). if the socket is live, the lead o.k. and the projector still doesnt start, there is a 20mm 1.6A (t1.6A) anti surge fuse inside the Projector IEC power inlet socket which blows in case of a mains fault. We pack a spare fuse so please check the box.

PLEASE NOTE faulty extension wiring can cause frequent lamp failure and is dangerous, use the IEC cable supplied by insight lighting. Please make sure any additional wiring is brand new, PAT tested or performed by competent or qualified personnel.

5. CONTROLS

- *if using a remote or interval timer, this plugs into the 6 pin socket on the rear of the projector
- * Kodak, Reflecta, ELMO interval timers, all allow 2-40 second intervals
Insight™ interval timers allow 2-120 second intervals
- *If using a dissolve unit, use the rectangular socket on the side of the machine with the INT/EXT switch in the EXT position.

6. TRANSPORTING

- *always transport projectors carefully in boxes provided and in an upright position
- * check the optics on arrival: common problems caused whilst transporting projectors are optics falling out due to vibration and internal damage due to rough handling.
- *never trust the plastic handles when carrying they tend to snap at the wrong moment. Preferably carry the whole machine by the body especially when working at height. When putting the projector at height always make sure it is secured, either with a simple right angle bracket or short safety bond attached to a solid fixing.

Troubleshooting:

A: Nothing happens?

1. Make sure the projector is plugged in and switched on and connected to a suitable 230v Power supply.
- 2 There is a **T1.6A** fuse built into the iec power inlet on the projector that protects the unit from electrical damage.
3. If the projector has been left unattended and a slide has jammed there is a thermal cut out that disables the projector until it has cooled down to a normal temperature. Identify and remedy the problem' **see SETTING UP 1** , replace slide tray and remount slide if necessary. try again.

B: Lamp wont light? Typically the fan is running but no light is showing.

- 1.the **Int/Ext** switch on the side of the projector disables the lamp for external control if this is switched to **ext** the lamp will not light.
2. **lamp blown?** A typical **A1/223 24V 250W** lamp made by osram, GE or philips will have a lamp life of 50-100 hours continuous usage.
a spare lamp is fitted and can be activated by the lever underneath the back of the projector which slides across from **lamp 1 to 2** as indicated on the back of the projector.
a third position is provided that allows you to eject the lamp from the lamp position to replace lamps.

access the lamps through the door on the side.

never handle hot lamps allow them to cool first
never handle a new lamp as the grease from fingers damages them.
make sure the lamp carriage goes back in to the horizontal position.

PLEASE NOTE faulty extension wiring can cause frequent lamp failure and is dangerous, use the IEC cable supplied by insight lighting. Please make sure any additional wiring is brand new, PAT tested or performed by competent or qualified personnel.

If in doubt phone us on the number below for more info.

C: Slides wont forward or reverse?

*If nothing happens when you press the slide forward and reverse buttons on the top of the projector and the fan/lamp is operating normally:

there is a **T1.25A fuse** on the inside of the projector on a circuit board by the handle. This usually only blows if the projector has been jammed on one slide. See also '**setting up. 1.**' before proceeding.

As this involves opening the Projector up we do not supply fuses for this remedy.
If in doubt phone us on the number below for more info.

*if the mechanism operates when you press the slide forward and reverse buttons on the top of the projector, but the slides do not change:
check the magazine is correctly fitted on the projector '**setting up. 3.**', then check your slides are not jammed in the projector. the magazine can be removed in an emergency using the metal spring locking mechanism in the centre of the magazine. do not force the magazine round. see setting up_1 and 3 before proceeding

*if something is resting the slide magazine (safety cable, power cabling, its wedged against the ceiling or other) it will not rotate. **See setting up. 2.**

D: Trouble focusing?

*always use uniform glass slide mounts for best uniform focusing results.

*dirty lenses? clean lenses with a lint free lens cloth and a suitable optic cleaner
don't use spirit cleaners like Acetone with plastic lenses.

*if the image is hard to focus check that the lamp is centred in position 1 or 2 and that the lamp carriage is returned to the horizontal position

*ensure the optics have not slipped out of position during transit. They should be located securely in the slots inside the side door. (PAGE 2 of the KODAK 2050 MANUAL)
*if the reflector has slipped from its slot, it is easiest to replace it whilst the projector is on it's side with the door facing upwards.(remove slides first)
*foreign objects inside the projector? bits of slide sometimes end up falling in and stop the light coming out. Take the lens out and look into the barrel. Any alien stuff you see can usually be removed by opening the door.
in the case none of these remedies work, perhaps the lens is faulty, or has come apart in the machine (removable lens barrels mostly) still no good? call us!

E.Noisy?

After many long years of use the Kodak SAV Projectors are likely to develop two kinds of noise:

Rattle: bearings and cam mechanism become worn. This suggests a full service is due,whilst not urgent, it is good to act fast to prevent permanent and irreparable damage.

Squeal: The Oil-light bearings have dried out as soon as this is detected, contact us for a service, if this continues for any length of time the projector will seize up, the fan will stop working the unit will overheat and the bearings will need replacing. Again, this suggests a full service is due. Act fast to prevent permanent and irreparable damage.

PLEASE NOTE using the wrong cleaning products and lubricants can be as bad as doing nothing at all, please check before using your own grease or solvents or call us on the number below to schedule a service.

*this piece of precision optical equipment has been lovingly restored for your enjoyment and benefit, so take care and have fun!

Insight Lighting :0208 806 3994 (open 9.30-5.30 mon-fri)

or call the mobile no. on the answerphone in an emergency

Bedienungsanleitung · Instruction Manual · Mode d'emploi
Manual de Instrucciones · Istruzioni per l'uso · Gebruiksaanwijzing
Bruksanvisning · Käyttöohje

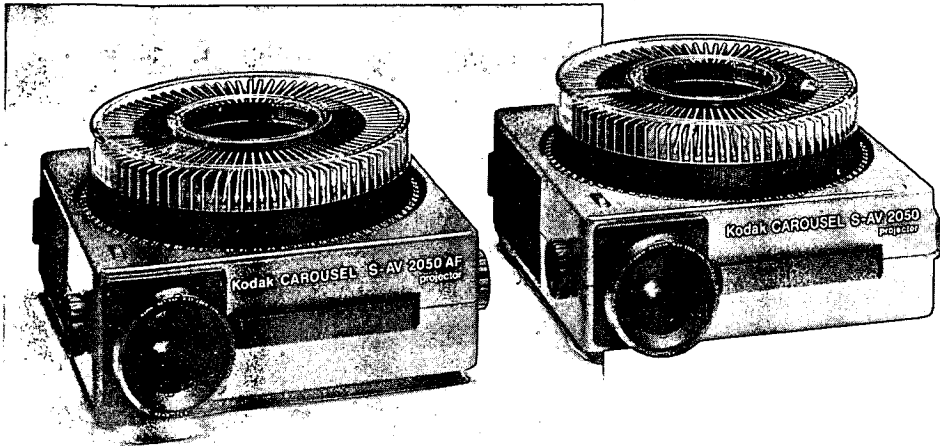

KODAK CAROUSEL S-AV 2050/ S-AV 2050 AF Projector



PROFESSIONAL PHOTOGRAPHIC DIVISION PRESENTATION TECHNOLOGIES

Kurzanleitung
Summary
Mode d'emploi résumé

Esquema resumido
Introduzione
Aanwijzingen in 't kort

Igångsättning
Johdanto

1.

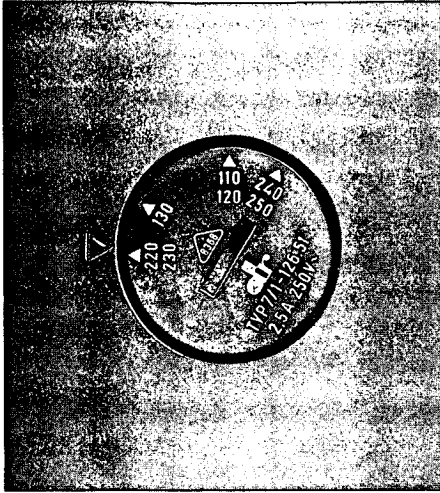

2.

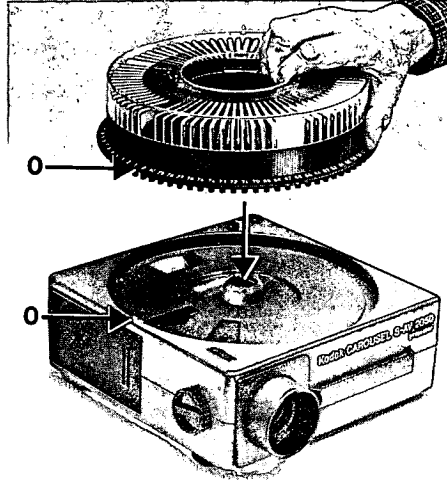

3.

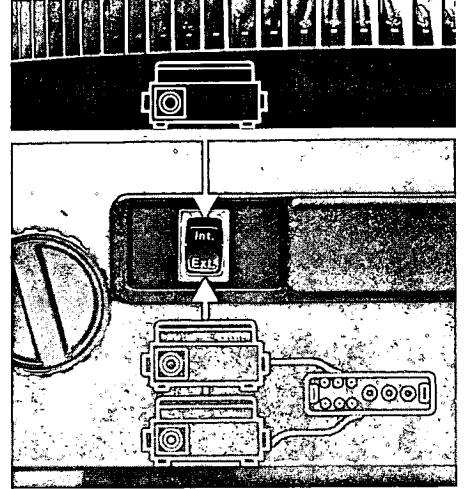

4.

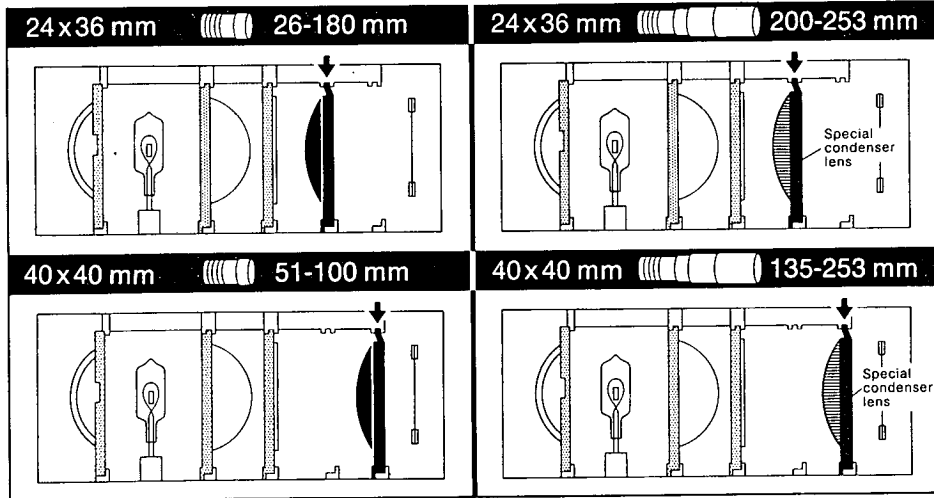

5.

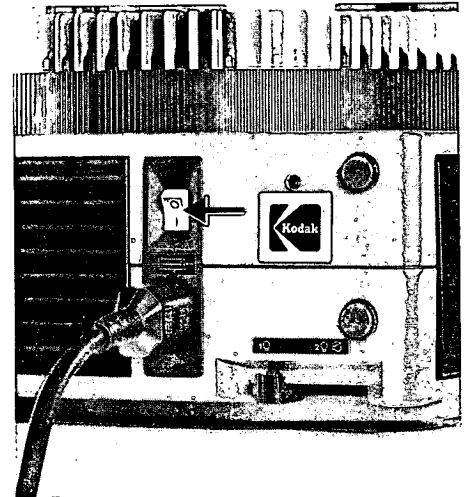

6.

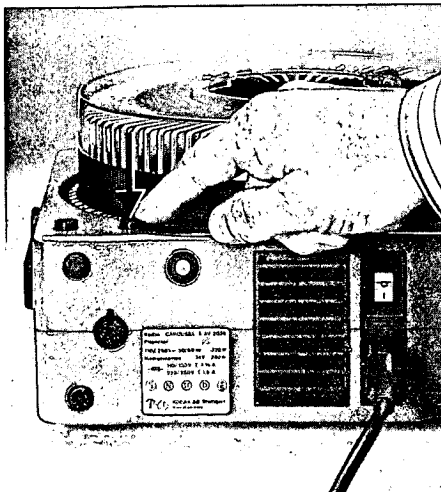

7.

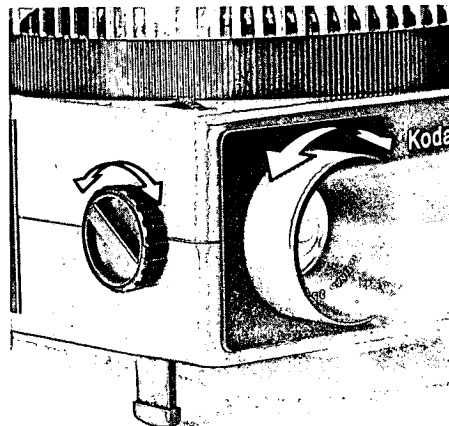

8.

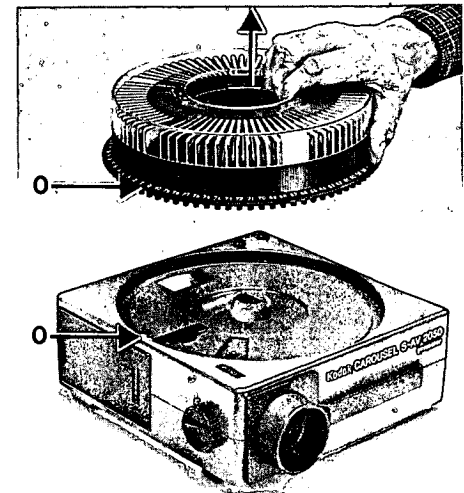

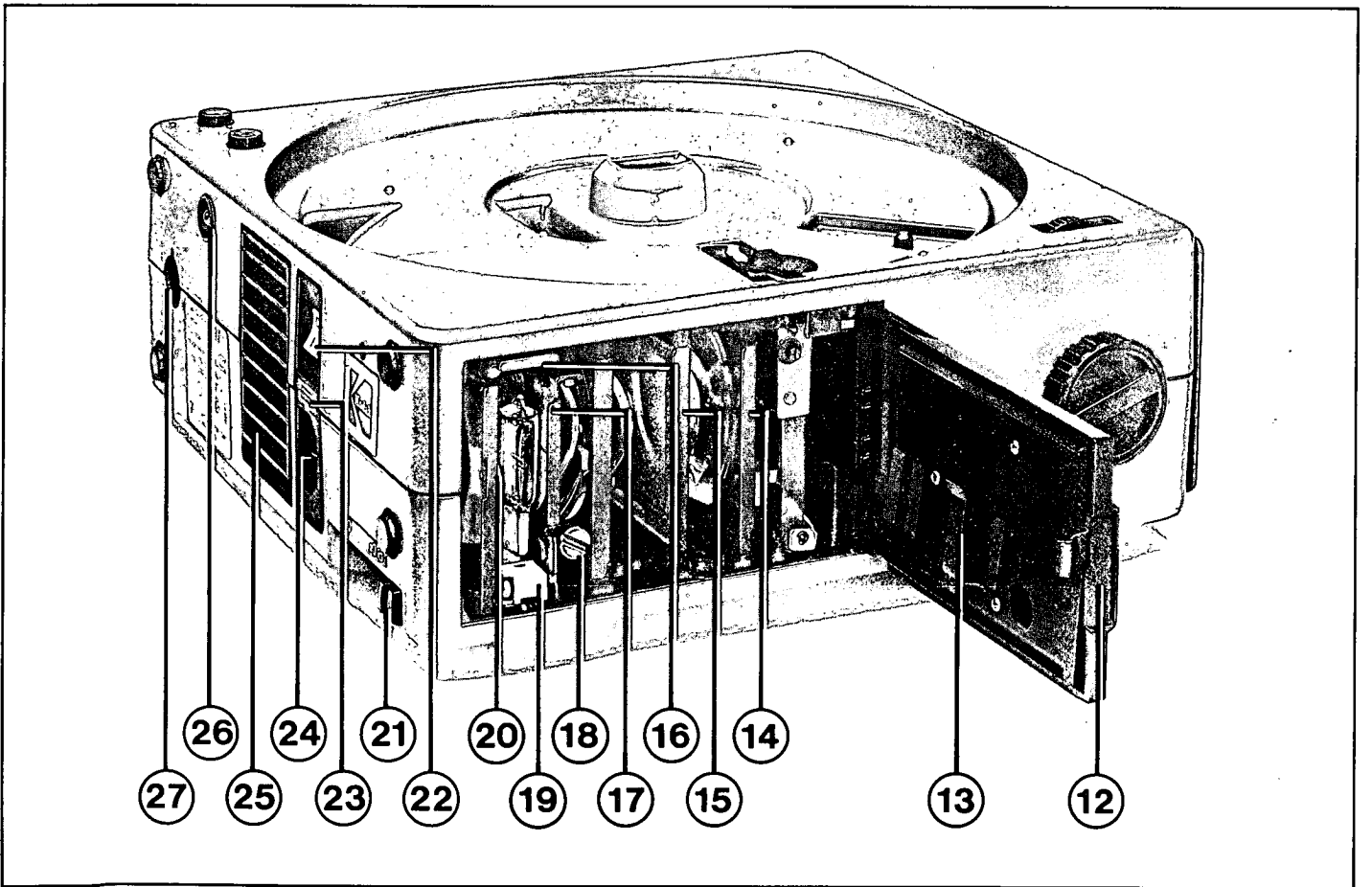
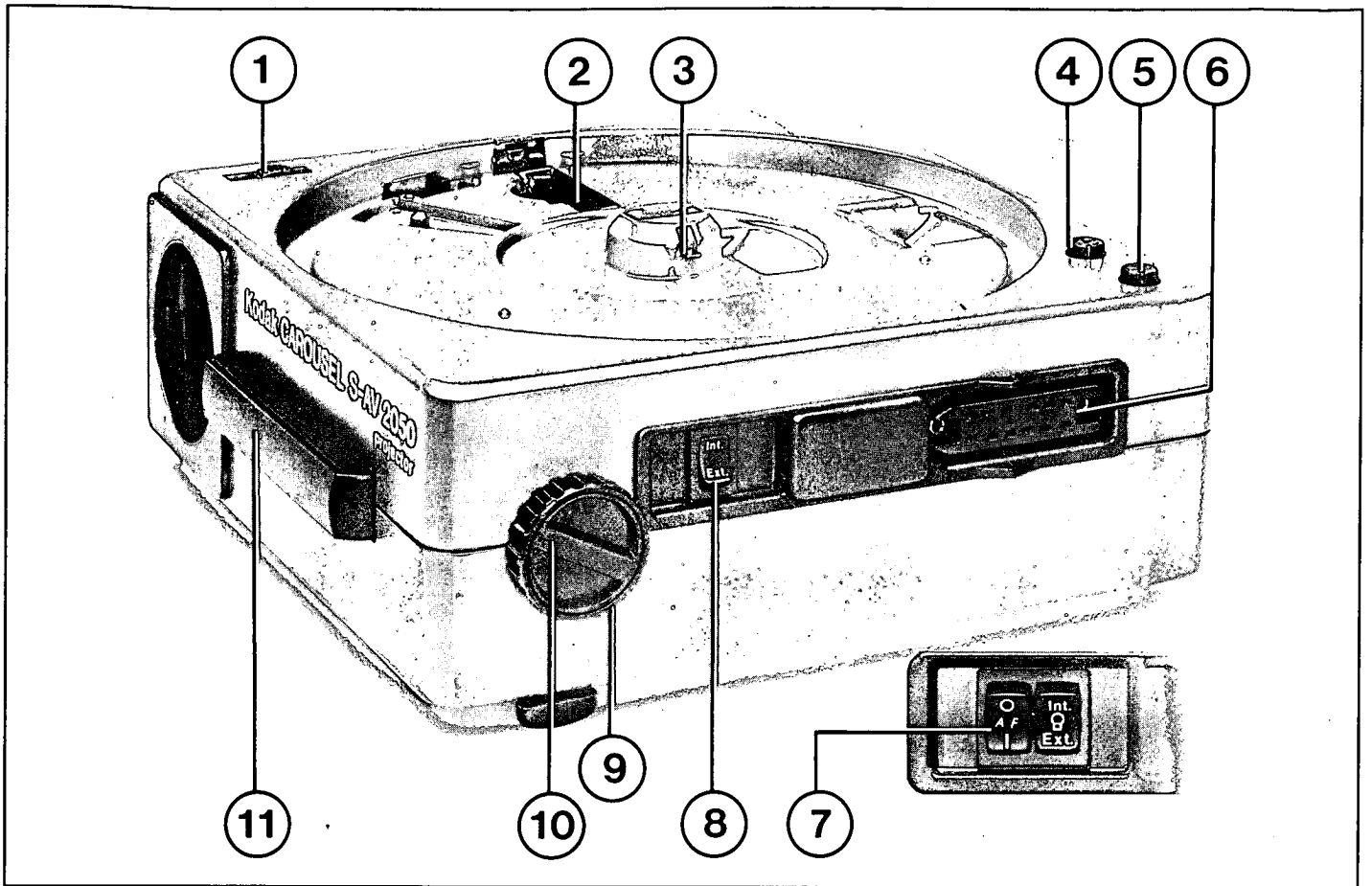

Projector features

- 1 Focusing knob for rack focusing lens
- 2 Slide gate
- 3 Slide tray lock
- 4 Forward slide-change and select button
- 5 Reverse slide-change button
- 6 12-pole socket
- 7 Autofocus on-off switch
- 8 Switch for external or internal lamp control
- 9 Height adjustment knob
- 10 Locking device for height adjuster
- 11 Retractable handle
- 12 Lamphouse door
- 13 Holder for additional spare lamp
- 14 Standard condenser lens (in position for 24 mm × 36 mm slides)
- 15 Heat filter
- 16 Lampholder latch
- 17 Lamp changeover lever
- 18 Lamp adjustment (horizontal)
- 19 Lamp socket with 2 lamps
- 20 Mirror adjustment (vertical)
- 21 Rapid lamp change lever
- 22 Mains switch
- 23 Fuse holder
- 24 Mains socket
- 25 Fan vent
- 26 Zero position indicator
- 27 6-pole socket

Using the instruction manual

Open out the front and rear cover flaps. These diagrams apply to the following text.

The principal stages of operating the projector are illustrated on the front flap in illustrations 1-8.

Switching-on the projector

Voltage selector (Figure P)

The voltage selector on the underside of the projector is set at manufacture to 220/230 V. Before altering the voltage selector, disconnect the mains supply and fit the correct fuse.

Mains fuse (Figure Q)

220/230 V or 240/250 V: 1.6 A slow blow fuse (already installed).
110/120 V or 130 V: 3.15 A slow blow fuse (packed separately).

The fuse must only be changed after the mains supply has been disconnected. Pull out the fuse holder (23) by pressure on the small catch. Remove the fuse and insert the new one.

The projector is supplied with a fuse or 220/250 V fitted.

Setting-up the projector

Place the projector on a firm, vibration-free base. The projector may be set at an angle of up to 30° from the horizontal in any direction. Check that the projector can draw in sufficient cold air for cooling and that warm air can be freely expelled. (The projector requires 20 litres of cooling air per second.) Keep air vents on the underside, at the rear of the projector, and on the lamphouse door, free from obstructions.

Note:

For fastening the projector in a fixed projection position, fixing holes suitable for self-tapping screws can be found in the back of the projector and in the base-plate (Figure).

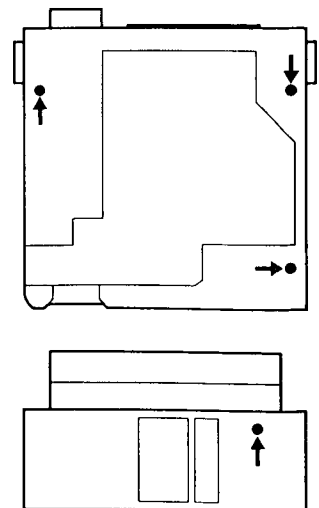

Slide mounts

The projector accepts all slides of 5 cm × 5 cm external size and up to 3.2 mm thick (complying with DIN 108). For a slide presentation it is important to use glass mounted slides throughout to avoid the need for refocusing.

Damaged, distorted or warped slides should not be used as they may disrupt the transport mechanism.

Fitting the slide tray (Figures R & S)

- Turn that transparent cover on the slide tray counter-clockwise and lift it off.
- Insert the slides into the tray.
- Replace the cover and lock it.
- Check that the baseplate of the slide tray is locked in position (Figure R). (When locked, the baseplate cannot be rotated.)
- Place the tray in its approximate position on the projector and rotate it until it locks in the zero position (Figure S).

Lenses

The KODAK RETINAR S-AV 1000 range of lenses, the high-precision KODAK RETINAR S-AV 2000 lenses and rack focusing lenses can be used.

For technical data on KODAK RETINAR S-AV 1000 and S-AV 2000 lenses see page 56.

The table of projected picture sizes (page 59) may help you to select the optimum lens focal length for each projection condition.

Key to table:

Scale a = Projection distance in metres

Scale c = Projected picture width in metres

Scale b_1 = Picture width of slide
24 × 36 mm horizontal format

Scale b_2 = Picture width of slide
24 × 36 mm vertical format

Scale b_3 = Picture width of slide
40 × 40 mm

Example: A projection distance of 10 m with 24 × 36 mm format (scale b_1) and a 150 mm lens produces a picture width of 2.30 m.

Condenser settings

(see summary on the front cover flap, Figure 4).

As supplied, the projector is fitted with the standard condenser lens (drawn in black in the diagram) in position for 24 × 36 mm slides.

For 40 mm × 40 mm slides, the standard condenser lens is put into the adjacent right-hand slot.

When using the 200 mm and 253 mm lenses, the standard condenser lens should be replaced by the special condenser lens supplied with these lenses. The special condenser lens is also recommended when projecting 40 mm × 40 mm slides with the RETINAR 135 mm, 150 mm and 180 mm lenses, giving better overall illumination.

Note: Ensure that the curved side of the standard condenser lens or special condenser lens is always facing the lamp.

Setting the lamp control

The position of the lamp control switch (8) depends on the application.

INT: Position for single projector mode. Lamp switching is controlled inside the projector.

EXT: Position for dissolve and multiple projector modes. The lamp only comes on when an external control unit is connected via the 12-pole socket (7).

Mains connection

Connect the projector to the mains with the 3.5 m mains lead supplied. Turn on the mains switch (22), the projection lamp comes on and the fan operates.

Centering the lamp (Figure T)

The projection lamp is adjusted at manufacture. **Only the correctly adjusted lamp yields maximum of brightness and gives optimum of durability.** Check the adjustment again before using the projector: it may have changed in transit.

- After switching off the projector, look through the lens and check the position of the lamp filament.
- 135 mm and longer focal length lenses: Place the pinhole slide enclosed with these lenses in the slide gate. Switch on the projector, fit the lens cap over the lens and observe the lamp filament images projected on the lens cap. Centre the lamp as shown below.

To be correctly adjusted the filaments must be in line and should not overlap (right-hand diagram).

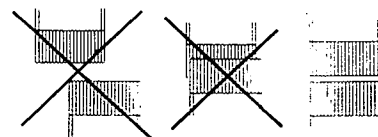

The left-hand diagrams show incorrect adjustments. To correct, proceed as follows:

- Open the lamphouse door (12).
- Turn the adjustment screw (18) for horizontal adjustment.
- Move the adjustment stud (20) up or down for vertical adjustment.

Levelling the projector (Figure U)

The height of the projector is adjusted by rotating the two knurled knobs (9), on the sides of the projector. They can then be locked in position by turning the inner knobs (10).

Operation

Focusing the image (Figure U)

Press the slide advance button (4): The first slide will transport into the slide gate and be projected.

Focus the projected image either by turning the lens or by turning the milled wheel (1) when using rack focusing lenses.

Autofocus (S-AV 2050 AF only)

The projector has an autofocus device which avoids the need to refocus manually. The infra-red focusing begins during the dark period. In dissolve mode, the operation of the autofocus is not visible on screen. With the over-ride feature it is still possible to have individual focusing by remote control – the autofocus is re-activated after the next slide change.

Before a show, the first slide must be focused manually. First switch on the autofocus (7) and then focus the image on the screen as described in "Focusing the image".

Note: In order to avoid large autofocus shifts during a slide presentation, it is recommended not to mix glass and glassless mounts in one show. For two or more projector dissolve shows use glass mounted slides only and switch off autofocus.

Slide-changing

1. Using the buttons on the Projector

- Forward slide change:
Press button (4) Ⓞ.
- Reverse slide change:
Press button (5) Ⓡ.
- Individual selection:
Press button (4) Ⓞ and hold it down. The slide tray can now be turned by hand to any position. Note that after releasing the button the slide tray moves forward one position.

2. Using the KODAK CAROUSEL Remote Control

For single projector operation, connect the plug on the remote control cable to the 6-pole socket (27) on the projector. In dissolve mode the cable is plugged into the appropriate socket on the dissolve unit.

The remote control operates the following functions:

Slide change forward. Ⓢ

Slide change reverse. Ⓡ

Focusing.

KODAK extension cables can extend the remote control cable up to 24 m.

3. With the KODAK Interval Timer

The KODAK Interval Timer is available for automatic slide changing at preset intervals. It can be set from about 4 to 40 seconds. In single projector mode it plugs into the 6-pole socket (27) on the projector.

4. With the KODAK S-AV Infrared Remote Control, Model TF, type II

This consists of a hand-held battery powered transmitter and a receiver. Forward and backward slide transport and focus can be controlled without cables up to a distance of about 30 metres from the receiver. The receiver can be attached to the projector (holder is supplied) and is plugged into the 6-pin socket (27).

Changing the slide tray (Fig. V)

Always lift off the slide tray in the zero position. By pressing button (4) the slide tray can be turned by hand to the zero position.

The zero position indicator (26) lights up when the slide tray is in the zero position, or has been lifted off.

In an emergency, e.g. transport failure, the tray can be removed from the projector in any position. To do this, push aside and hold the slide tray centering latch (3) while lifting off the slide tray. Remove the slide from the slide gate.

Having removed the slide tray, turn it over and rotate the base plate until it locks in position. Otherwise the slide tray cannot be replaced on the projector.

Rapid lamp changer (Figure W)

With the rapid lamp changer (21), the spare lamp (L₂) can be brought into use immediately if the normal lamp (L₁) fails.



- Push the rapid lamp changer (21) to the right to position 2 . The spare lamp is now ready to be used.

The spare lamp (L₂) may not be perfectly centered, but illumination evenness should be adequate for completion of a show. After the slide show insert a new lamp (L₁) and center it.

Other projection modes

Replacing a defective lamp (Figures X and Y)

Unplug the mains lead before replacing a defective lamp! Let the projector cool before you touch the lamp and the part around it!

- Open the lamphouse door (12).
- Push the rapid lamp changer (21) to the right until it stops .
- Swing out the lamp changeover lever (17) until the lampholder latches into position.
- Remove the defective lamp. Always handle lamps by the protective sleeve when inserting to avoid getting fingerprints on the glass. When the lamp is in place, remove the sleeve.
- Push up the lampholder latch (16) and swing back the lever (17).
- Push the rapid lamp changer (21) fully to the left into the operating position .
- Centre the operating lamp (L₁).

A further spare lamp can be accommodated in a holder (13) on the inside of the lamphouse door.

Continuous projection with 81 slides

Before putting on the full slide tray, insert an additional 81st slide in the slide gate.

For automatic slide changing, plug the KODAK Interval Timer into the projector's 6-pole socket (27).

Dissolve and multi-projection mode

For dissolve and multi-projection mode, the projector can be connected to external control units via the 12-pole socket (6) (see Technical data).

Note: Always use the original KODAK accessory!

- Press switch (8) to **EXT**. In this setting, the lamp is controlled by an external control unit.

The KODAK range of accessories includes control units for dissolve and multi-projection modes:

- The KODAK S-AV Programmable Dissolve Control is a microprocessor controlled digital dissolve unit for two projectors with 12-pole standard socket. It can make AV programmes with a wide range of visual effects. The keyboard provides five dissolve rates, as well as several special effects.

An outstanding feature of the unit is its built-in protection against loss of sound and slide synchronization.

The dissolve control can form part of more complex multivision installations. The auxiliary connector permits other control functions to be programmed: e.g. a third projector, tape stop and restart, film projector, strobe, or room lights.

- The KODAK CAROUSEL S-AV Dissolve Control Model B can be used in impulse mode, frequency-modulation mode or in digital mode. The control pulses can be transferred direct onto a tape recorder.

Zero-position indicator

To enable the operator to recognize immediately when all projectors in a multi-projector presentation are zeroed, the projector is fitted with a zero-position-indicator (LED) (26) which lights when the slide tray is zeroed.

Snap facility (Figure A)

The snap facility is an electromagnetically controlled shutter, built into the projector, which can be controlled via the projector's 12-pole socket. The light path from the projection lamp can be suddenly cut off and then restored, making numerous visual effects possible (see Technical Data).

Slide change times

The KODAK CAROUSEL S-AV 2050, 2050 AF and 2054 Projectors have a slide-change time of one second instead of 1.5 seconds with earlier S-AV projectors.

For this reason, slide presentations which are programmed with a slide-change time faster than 1.5 seconds cannot be projected efficiently on KODAK CAROUSEL S-AV 2000, 2020 and 2030 Projectors. However, slide presentations which were programmed with these projectors can be run on the faster models without difficulty.

Tape Control of a Single Projector (Figure Z)

In single projector slide-tape presentations, the slide change is simply controlled by the tape recorder. The recorder must be fitted with an AV head with a built-in slide control unit or have an external slide control unit connected. (Control pulse duration: 0.2 to 0.75 seconds with 50 Hz; 0.18 to 0.6 seconds with 60 Hz.)

The connection to the projector is made via the 6-pole socket (27).

The KODAK CAROUSEL Twin Socket Model B together with the KODAK Remote Control Cable, permits remote focusing during tape recorder control.

Projection in parallel

With parallel projection, the projectors linked in parallel are simultaneously operated, either by remote control, interval timer or slide control unit. To do this, a connection cable to the twin socket and a KODAK CAROUSEL Twin Socket, Model B are required for each additional projector.

Maintenance

Dirt and dust can have adverse effects on the lubricants used in the projector and thus cause malfunctions. Therefore the projector and the slide tray should be returned to the KODAK Customer Service Department after approximately 1500 hours of operation.

Where the projector is used in very dusty locations (e.g. exhibitions) more frequent servicing may be advisable.

Cleaning of the projector optics, such as the lens, condenser and heat filter should be carried out using a soft lint-free cloth or camel hair brush.

The heat filter fits loosely into its holder to allow room for expansion as it gets warm. Take care not to bend the holder during cleaning.

Possible problems during operation

- Lamp fails to light, but the fan operates:
 - Switch for lamp control (8) in wrong position.
 - Defective lamp.
- Projected image insufficiently illuminated:
 - Condenser lens in wrong position.
 - Wrong condenser lens fitted.
 - Lamp not centered.
 - Lamp changeover lever not exactly in position 1 or 2.
- Switching on the projector, the lamp fails to light and the fan does not operate:
 - Fuse blown.
 - Thermal overload cut-out has switched the projector off.
- Slide transport problem:
 - Slide damaged.
 - Magazine base plate not located in zero position.
 - Magazine base plate bent.
 - Remote control cable exceeds the permitted 24 m extension.
 - Slide transport pulse too short.

- KODAK RETINAR S-AV 1000 range of lenses and high-precision KODAK RETINAR S-AV 2000 lenses in various focal lengths (see page 56; 57 figure N and O).
- KODAK CAROUSEL S-AV 2000 Slide Tray with transparent cover. The slide trays hold up to 80 slides (Figure K).
- KODAK CAROUSEL Remote Control (4 m) (Figure F), plus Extension Cables 4 m and 16 m.
- KODAK S-AV Infrared Remote Control, Model TF, type II, for lead-less remote control of the projector up to about 30 metres (Figure G).
- KODAK CAROUSEL Interval Timer, adjustable from approximately 4 to 40 seconds (Figure H).
- KODAK CAROUSEL Twin Socket, Model B for simultaneous connection of a Remote Control and a slide synchronizer. Also used for parallel connection of projectors (Figure I).
- KODAK S-AV Cassette Recorder 200, mono audio recorder with built-in AV control track facility; capable of controlling slide changes on one or two projectors independently. With single projector control, automatic tape stops can be programmed. Control signals from external dissolve units can also be recorded (Figure L).
- KODAK S-AV Programmable Dissolve Control for two projector tape-slide presentations with a wide range of effects (Figure M).
- KODAK CAROUSEL Carrying Case (Figure J).

Technical data

Gravity feed slide change with pressure levers in two planes to ensure good slide alignment.

Slide format up to 40 mm × 40 mm. Maximum slide thickness 3.2 mm (DIN 108).

Universal lens mount for KODAK RETINAR Lenses and lenses with rack focus.

Slide change time: 1 second with 50 Hz operation; 0.9 seconds with 60 Hz operation.

Height setting to a maximum of 6° via two locking, adjusting knobs.

The projector will also function on a slope of up to 30° in any direction.

Illumination

Two 24 V/250 W halogen lamps (G6,35-EHJ, Cat. 709 2539) fitted on a rapid lamp changer (operational lamp and spare lamp).

300 hours of average lamp life. For replacement lamp can be swung out.

Lamp control switch, internal or external depending on projection mode.

Effective light intensity of approximately 950 lumens with 24 mm × 36 mm slides and with KODAK RETINAR 93 mm lens.

Interchangeable condenser system for slide formats 24 mm × 36 mm and 40 mm × 40 mm, and for lenses with longer focal lengths.

Operation range (Figure B)

The permissible operating range of the projector depends on the ambient temperature and the mains voltage.

- a = Ambient temperature (°C)
- b = Mains voltage
- c = Nominal voltage
- d = 15% Undervoltage
- e = 10% Overvoltage
- f = Lamp voltage

Should the projector overheat, e.g. due to lack of cooling air or jamming of the slide transport mechanism, the built-in thermal cut-out automatically switches off the projector and then switches it on again, once it has cooled down.

Electrical system

Voltage selector for:
110/120 V; 130 V; 220/230 V; 240/250 V
Frequency: 50/60 Hz.

Total power consumption:
approximately 320 W.

Fuses:

- a) Primary circuit
 - for 220/230 V or 240/250 V: 1.6 A slow blow.
 - for 110/120 V and 130 V: 3.15 A slow blow.
- b) Secondary circuit: 1.25 A slow blow.

The projector meets electrical safety requirements of VDE, Class 1. Interference suppressed (FN VDE 0875). This equipment conforms with the requirements of EEC Directive 76/889 with respect to radio interference.

Control system

Push buttons for slide changing: forward (with additional possibility of manual slide selection) and reverse.

Zero-position indicator (LED) which lights when the slide tray is zeroed

Snap facility making numerous visual effects

12-pole standard socket (Figure C) with connections for dissolve units

Socket connections:
 $a_1 + a_4 = 24$ V a.c. (maximum load 750 mA rms).

$b_4 + a_5 = 20$ V pulsed d.c. (maximum load 750 mA rms).

$a_3 + a_4 =$ external control.

$b_5 + b_6 =$ slide tray zero reset.

$a_6 =$ zero reset switch in gate (for zero reset signal).

$b_3 + b_4 =$ forward slide change (pulse duration 0.2 to 0.75 seconds with 50 Hz, and 0.18 to 0.65 seconds with 60 Hz).
Slide changing is continuous with a continuous pulse.

$b_2 + b_4 =$ reverse slide change (pulse duration 0.3 to 0.85 seconds with 50 Hz, and 0.27 to 0.7 seconds with 60 Hz).
With activated snap change pulse duration 0.7 to 0.8 seconds with 50 Hz, and 0.6 to 0.7 seconds with 60 Hz).

$b_1 + b_4 =$ snap change (pulse duration ≥ 0.18 sec).

6-pole DIN socket, Figure D, to take CAROUSEL Remote Control, KODAK Interval Timer, KODAK S-AV Infrared Remote Control, Model TF, Slide Control Units, and Programmer.

Connections 2 + 3 = Forward slide change.

Connections 1 + 3 = Reverse slide change. (Pulse duration as for $b_3 + b_4$ and $b_2 + b_4$ of the 12-pole socket.)

For control purposes, connections 6 + 3 can supply approx. 20 V d.c. at a maximum current of 750 mA.

S-AV 2050 AF Projector:
Automatic slide focusing using infrared radiation reflected by the slide; over-ride feature included. Autofocus on-off by switch (7).

Wiring diagram of S-AV 2050 Projector see page 52.

Wiring diagram of S-AV 2050 AF see page 53.

Dimensions (Figure E)

Length: 262 mm
Width: 284 mm
Height: 101 mm
Height with slide tray: 151 mm
Weight (without slide tray): approx. 7600 g.
Weight of slide tray: 540 g

Equipment subject to minor appearance changes.

KODAK, CAROUSEL and RETINAR are trade marks.

KODAK CAROUSEL S-AV 2050 Projector

110/120V	11-12	1-2	2-7	
130V	11-12	1-2		6-7
220/230V	12-1		2-7	
240/250V	12-1			6-7

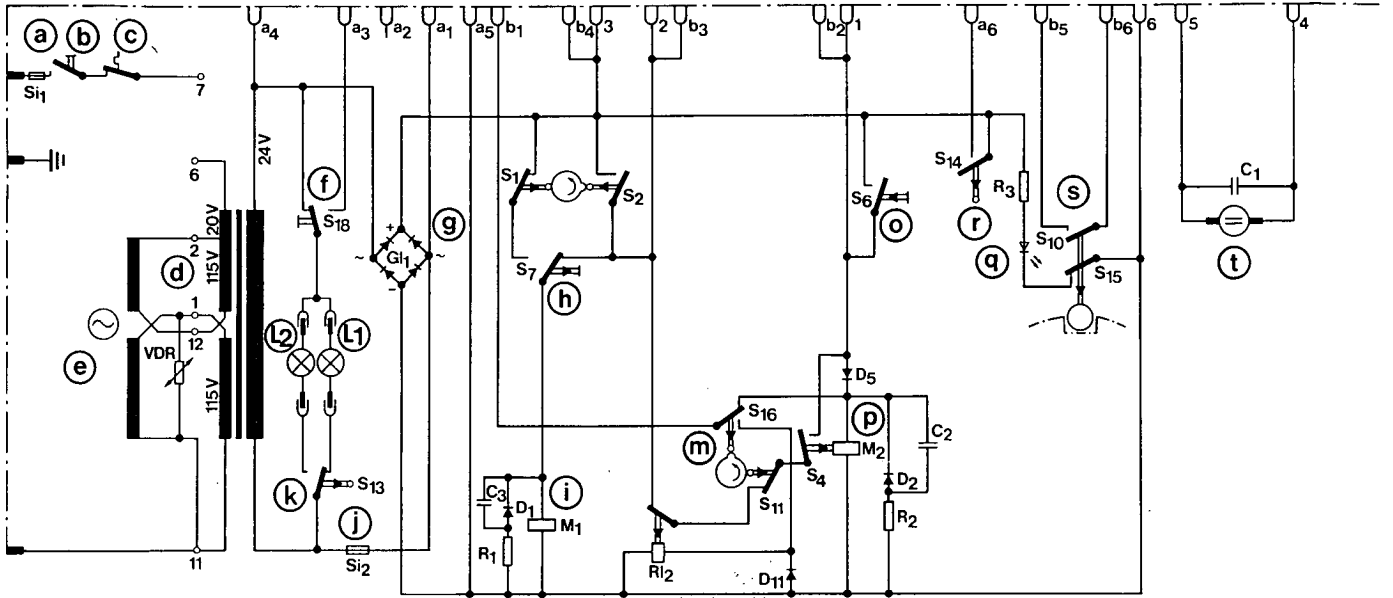
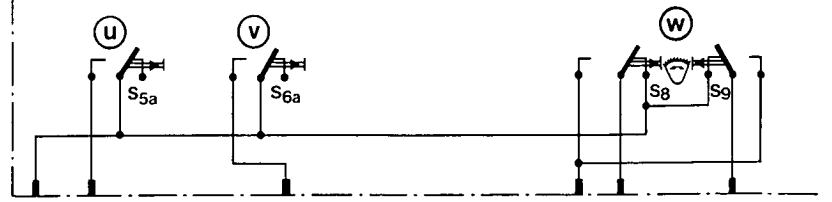

Schaltplan

- a = Netzsicherung
- b = Netzschalter
- c = Wärmeschutzschalter
- d = Spannungswähler
- e = Spaltpolmotor
- f = Schalter für interne bzw. externe Lampensteuerung
- g = Gleichrichter
- h = Diatransport vorwärts und freie Diawahl
- i = Kupplungsmagnet
- j = Sekundärsicherung
- k = Schalter für Umschaltung auf Reservelampe
- L₁ = Betriebslampe
- L₂ = Reservelampe
- m = Schalter für Tachystoskop
- o = Diatransport rückwärts
- p = Umschaltmagnet für Vorwärts-/Rückwärtstransport und Tachystoskop
- q = Leuchtdiode für Nullstellung
- r = Nullstellungsschalter im Fallschacht
- s = Magazin-Nullstellungsschalter
- t = Fokussiermotor
- u = Fernbedienung vorwärts
- v = Fernbedienung rückwärts
- w = Fernbedienung Fokussierung
- x = Autofocus ein/aus (nur S-AV 2050 AF)

Wiring diagramm

- a = Mains fuse
- b = Mains switch
- c = Thermal overload cut-out
- d = Voltage selector
- e = Shaded pole motor
- f = Switch for internal or external lamp control
- g = Rectifier
- h = Forward slide change and select
- i = Clutch solenoid
- j = Secondary fuse
- k = Switch for lamp changeover
- L₁ = Lamp in circuit
- L₂ = Spare lamp
- m = Switch for snap change
- o = Reserve slide change
- p = Reserving solenoid for forward/reverse slide change and snap change
- q = LED for zero position
- r = Zero reset switch in slide gate
- s = Slide tray zero position switch
- t = Focusing motor
- u = Remote control forward
- v = Remote control reverse
- w = Remote control focusing
- x = Autofocus on/off (S-AV 2050 AF only)

Plan de câblage

- a = fusible
- b = commutateur marche/arrêt
- c = disjoncteur thermique
- d = sélecteur de tension
- e = moteur asynchrone
- f = commutateur pour la commande interne et externe de la lampe
- g = redresseur
- h = marche avant et projection d'une vue sélectionnée
- i = électro-aimant d'inversion de la marche
- j = fusible secondaire
- k = contacteur pour la commutation de la lampe de réserve
- L₁ = lampe en service
- L₂ = lampe de réserve
- m = contacteur du tachystoscope
- o = marche arrière
- p = contacteur marche avant/marche arrière et tachystoscope
- q = diode lumineuse de l'indicateur de la position zéro
- r = capteur de position 0 dans le couloir vertical
- s = contacteur de retour à zéro du magasin
- t = monteur de mise au point
- u = commande à distance marche avant
- v = commande à distance marche arrière
- w = commande à distance mise au point
- x = mise au point automatique marche/arrêt (S-AV 2050 AF uniquement)

Esquema del cableado

- a = Fusible de la red
- b = Interruptor principal de encendido/apagado
- c = Interruptor térmico de sobrecarga
- d = Selector de voltaje
- e = Motor asincrónico
- f = Interruptor para el control interno o externo de la lámpara
- g = Rectificador
- h = Avance de la diapositiva y selección
- i = Solenoide del embrague
- j = Fusible secundario
- k = Interruptor para el cambio de la lámpara
- L₁ = Lámpara dentro del circuito
- L₂ = Lámpara de repuesto
- m = Interruptor del tachistoscopio
- o = Retroceso de la diapositiva
- p = Solenoide de inversión para cambio de marcha; avance/retroceso y obturación rápida
- q = Indicador LED de posición cero
- r = Interruptor de puesta a cero en la ventanilla de proyección
- s = Interruptor de puesta a cero en la bandeja de diapositivas
- t = Motor de enfoque
- u = Avance por control remoto
- v = Retroceso por control remoto
- w = Enfoque por control remoto
- x = Interruptor de enfoque automático (S-AV 2050 AF)

KODAK CAROUSEL S-AV 2050 Projector

110 / 120 V	11-12	1-2	2-7	
130 V	11-12	1-2		6-7
220 / 230 V	12-1		2-7	
240 / 250 V	12-1			6-7

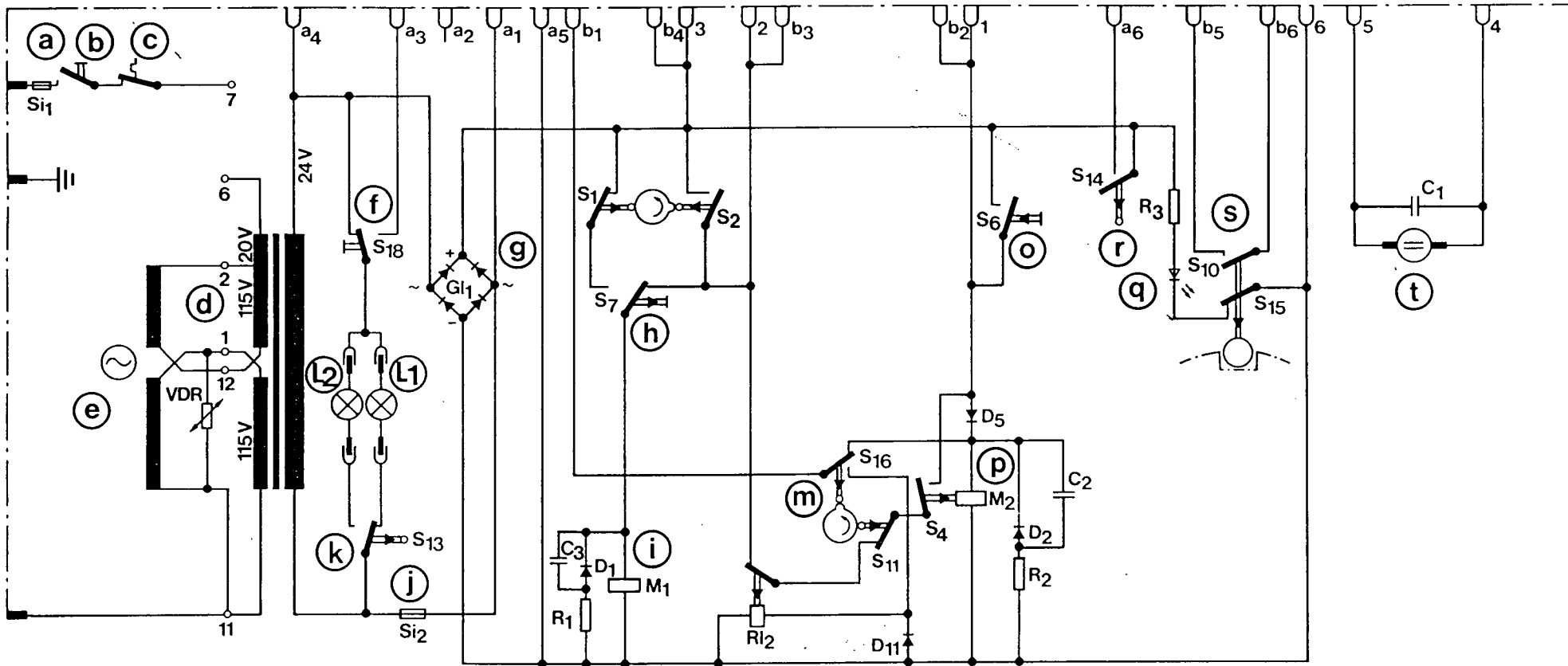
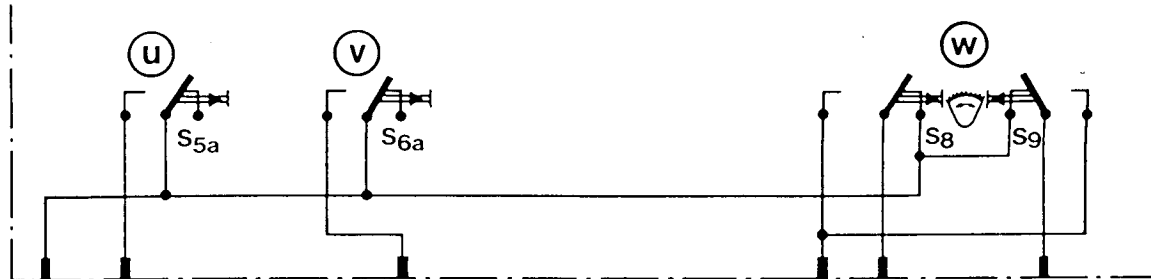

Schaltplan

- a = Netzsicherung
- b = Netzschalter
- c = Wärmeschutzschalter

Wiring diagramm

- a = Mains fuse
- b = Mains switch
- c = Thermal overload cut-out

Plan de câblage

- a = fusible
- b = commutateur marche/arrêt
- c = disjoncteur thermique

Esquema del cableado

- a = Fusible de la red
- b = Interruptor principal de encendido/apagado

KODAK CAROUSEL S-AV 2050 AF Projector

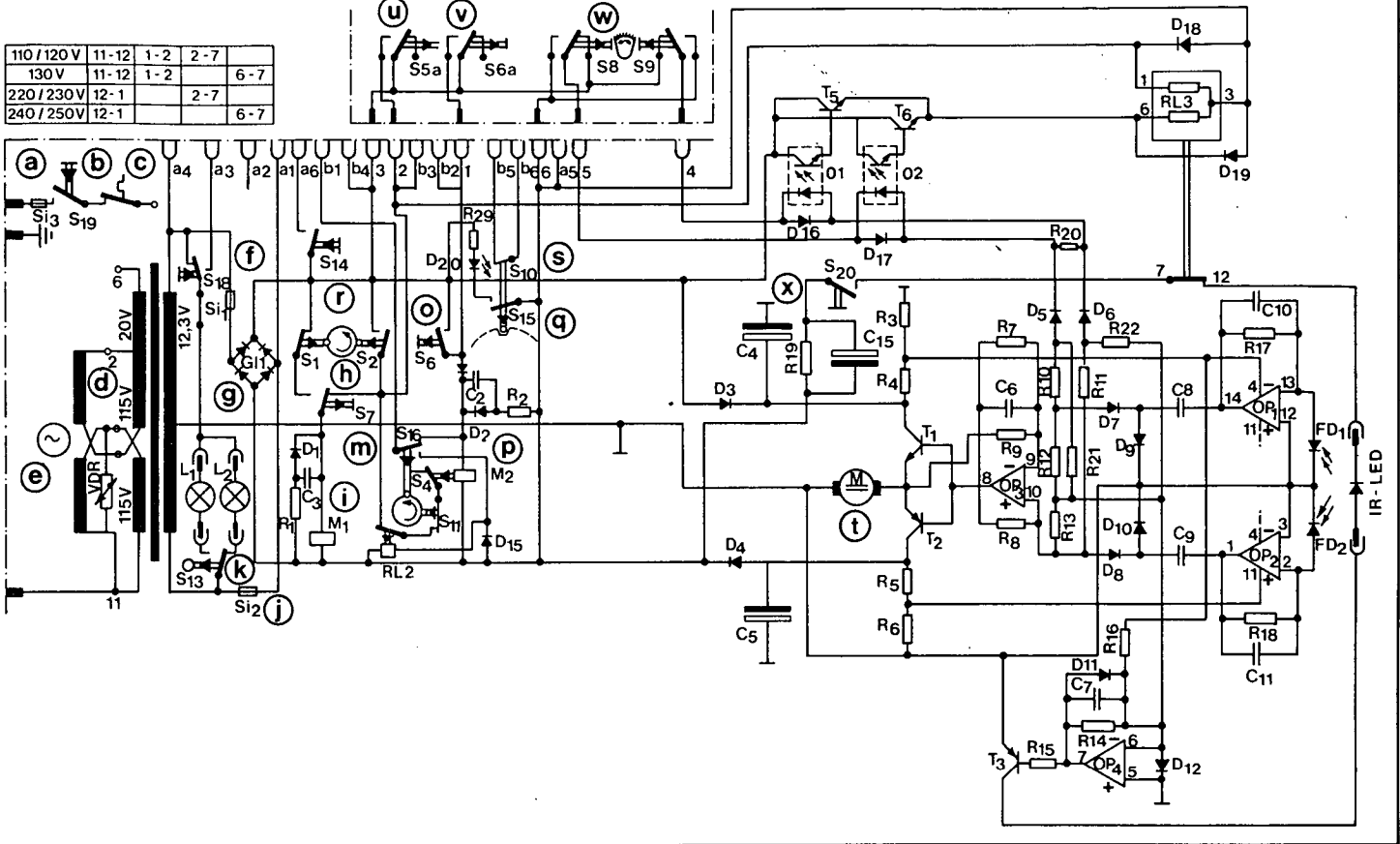

Schema elettrico

- a = fusibile
- b = interruttore
- c = interruttore termico di sicurezza
- d = selettore di tensione
- e = motore asincrono
- f = interruttore per comando lampada interno/esterno
- g = raddrizzatore
- h = interruttore per cambio diapositiva in avanti e selezione delle diapositive
- i = solenoide
- j = fusibile secondario
- k = interruttore per commutazione sulla lampada di riserva
- L₁ = lampada di esercizio
- L₂ = lampada di riserva
- m = interruttore per l'otturatore rapido
- o = trasporto diapositiva in avanti
- p = solenoide per cambio diapositiva avanti/indietro e comando otturatore rapido
- q = diodo ottico di azzeramento
- r = interruttore di azzeramento nel vano di caduta
- s = interruttore di azzeramento del caricatore
- t = motorino per la messa a fuoco
- u = comando a distanza in avanti
- v = comando a distanza all'indietro
- w = comando a distanza per la messa a fuoco
- x = interruttore dell'autofocus (solo nel modello S-AV 2050 AF)

Schakelschema

- a = netzekering
- b = netschakelaar
- c = thermische beveiliging
- d = spanningskiezer
- e = kortsluitankermotor
- f = schakelaar voor in- of externe lampschakeling
- g = gelijkrichter
- h = diatransport vooruit en keuze willekeurige di
- i = koppelmagneet
- j = secundaire zekering
- k = schakelaar voor om-schakeling op reservelamp
- L₁ = in gebruik zijnde lamp
- L₂ = reservelamp
- m = schakelaar voor Tachystoscoop
- o = diatransport achteruit
- p = schakelmagneet voor transport voor/achteruit en Tachystoscoop
- q = LED voor nulstand
- r = nulstelschakelaar in beeldvenster
- s = nulstelschakelaar magazijn
- t = scherpstelmotor
- u = afstandsbediening vooruit
- v = afstandsbediening achteruit
- w = afstandsbediening scherpstelling
- x = autofocus aan/uit (alleen S-AV 2050 AF projector)

Kopplingschema

- a = Nätsäkring
- b = Huvudströmbrytare
- c = Termosäkring (överhettningsskydd)
- d = Spänningsomkopplare
- e = Spaltnmotor
- f = Brytare för intern resp. extern lampstyrning
- g = Likriktare
- h = Diatransport framåt och fritt diaval
- i = Kopplingsmagnet
- j = Sekundärsäkring
- k = Brytare för omställning till reservlampa
- L₁ = Driftslampa
- L₂ = Reservlampa
- m = Brytare för "snap-change"
- o = Diatransport bakåt
- p = Omkopplingsmagnet för matning framåt/bakåt och "snap-change"
- q = Lysdiod för nollställning
- r = Nollställningsbrytare i fall-schakt
- s = Nollställning av magasinet
- t = Skärpeinställningsmotor
- u = Fjärrkontroll framåt
- v = Fjärrkontroll bakåt
- w = Fjärrkontroll skärpeinställning
- x = Autofokus (på/av)

Kytlinkaavio

- a = pääsulake
- b = pääkytkin
- c = yllilämpösuoja
- d = jännitteen valitsin
- e = suojamaadoitettu oikosulku-moottori
- f = lampun ohjaukytkin
- g = tasasuuntaaja
- h = dian siirto eteenpäin ja valinta
- i = kytkinsolenoidi
- j = toisiosulake
- k = lampunvaihtokytkin
- L₁ = lampun virtapiiri
- L₂ = varalamppu
- m = pikavaihtokytkin
- o = suunnanvaihtosolenoidi dian siirrolle
- p = eteenpäin/taaksepäin ja pikavaihto
- q = nolla-asennon ilmaiseva LED
- r = kuvaportissa oleva nollauskytkin
- s = diakasetin nollauskytkin
- t = objektiivin tarkennusmoottori
- u = kauko-ohjaus eteenpäin
- v = kauko-ohjaus taaksepäin
- w = kauko-ohjaustarkennus
- x = automaattitarkennuksen kytkin (vain S-AV 2050 AF)

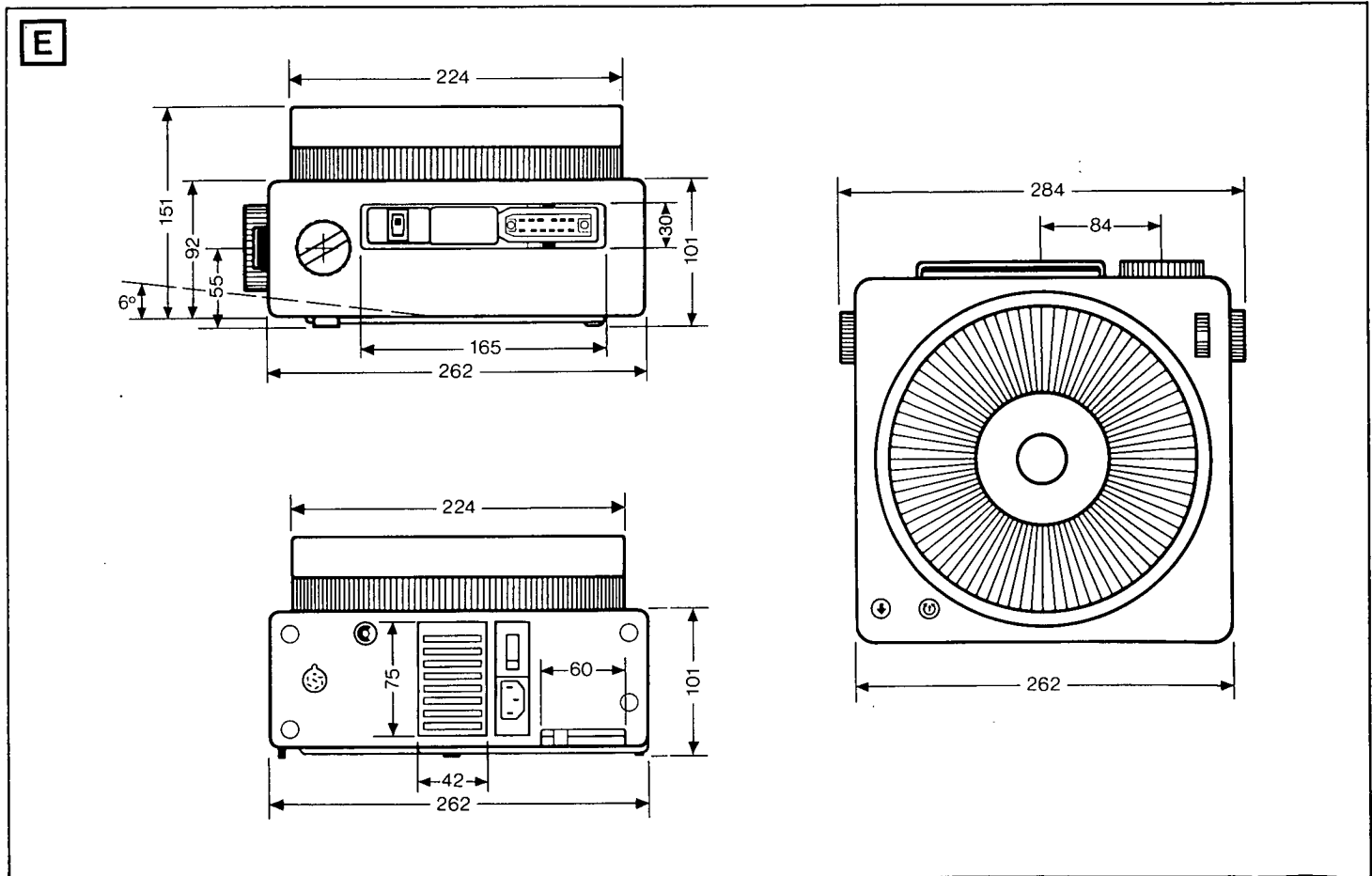
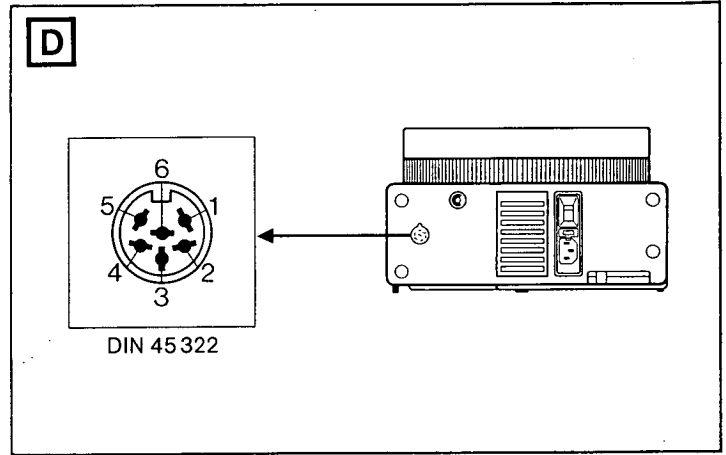
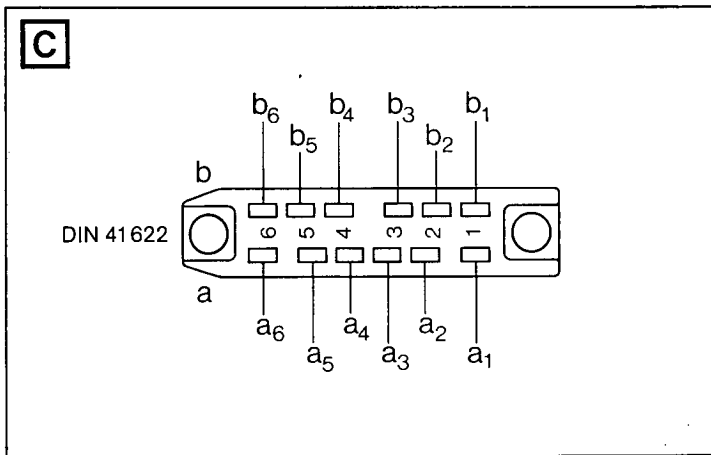
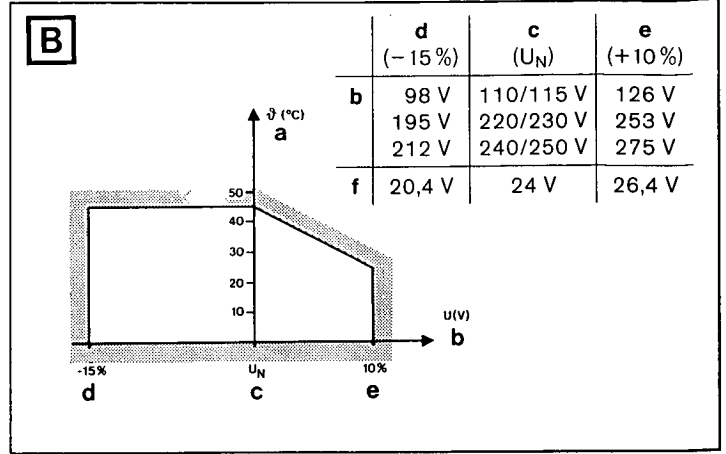
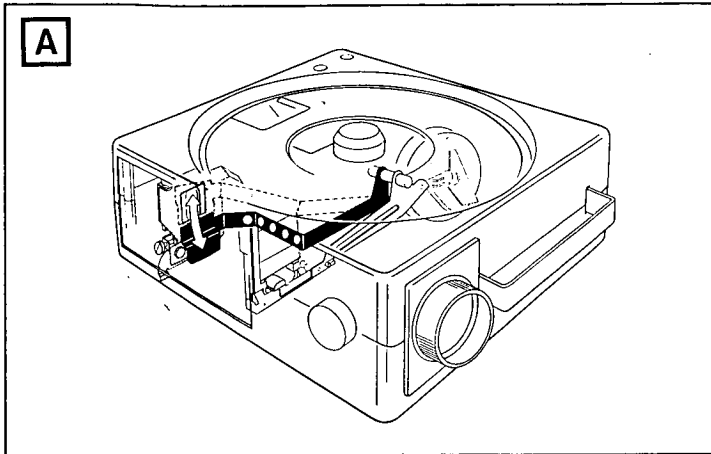

ZUBEHÖR
ACCESSORIES
ACCESSOIRES
ACCESORIOS

ACCESSORI
TOEBEHOREN
TILLBEHÖR
TARVIKKEET

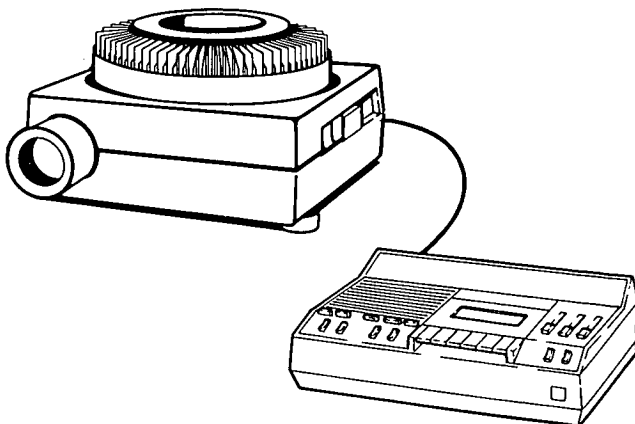
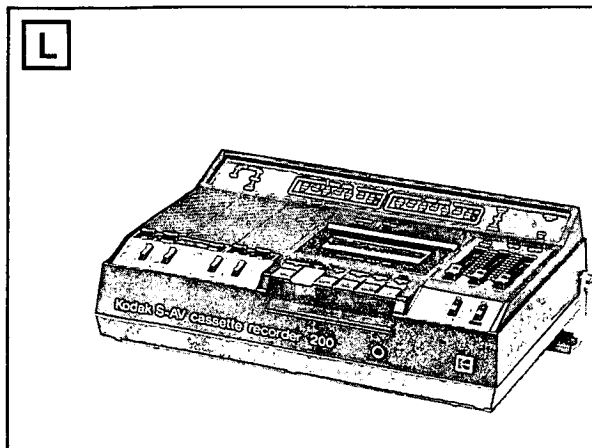
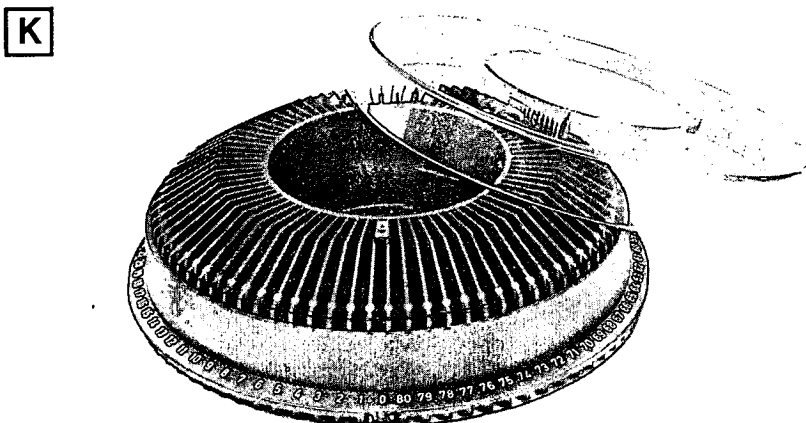
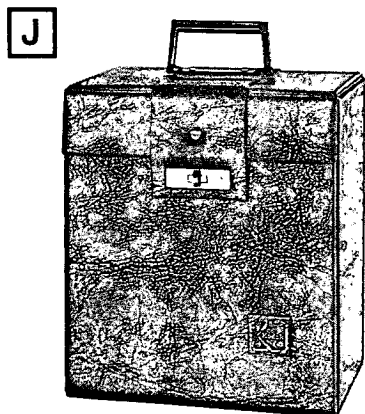
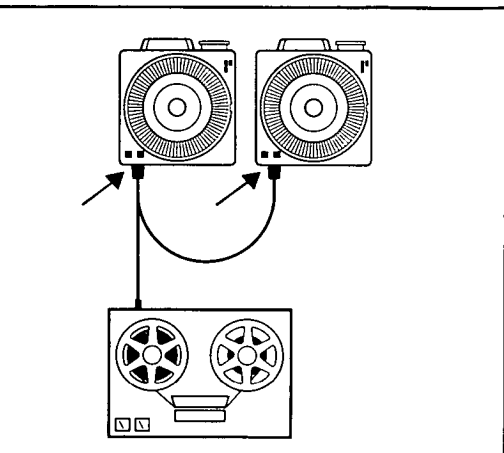
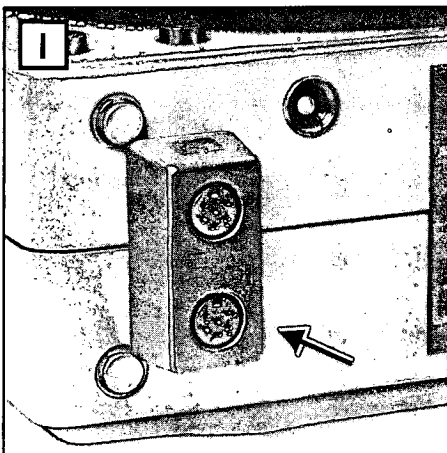
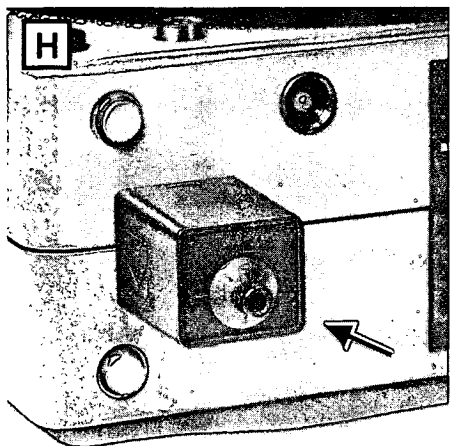
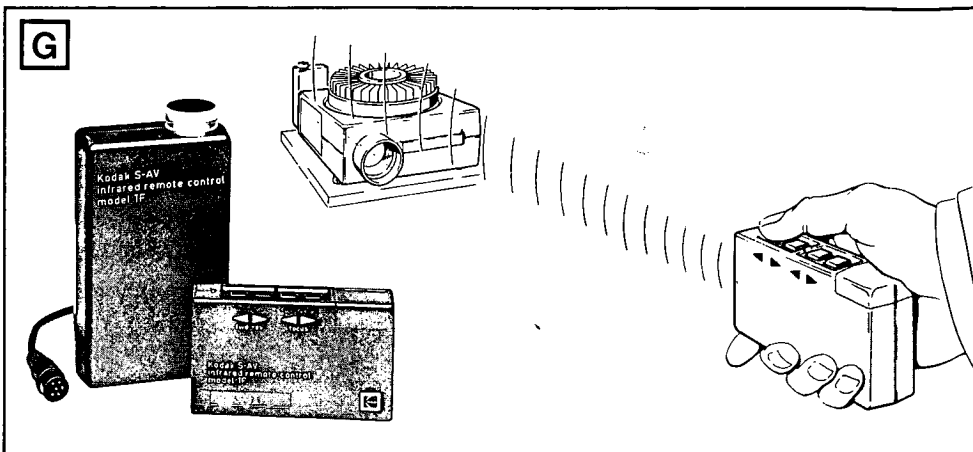
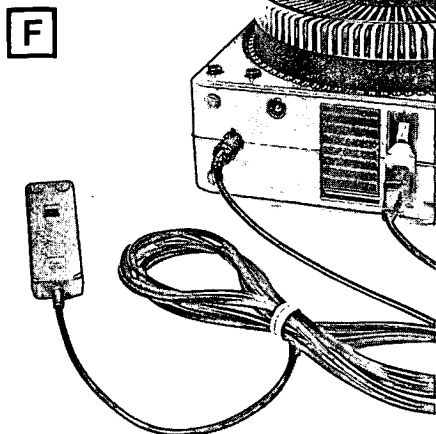

KODAK RETINAR S-AV 1000 und S-AV 2000 Objektive

KODAK RETINAR S-AV 1000 and S-AV 2000 Lenses

KODAK RETINAR S-AV 1000 Lenses		55 mm	85 mm	100 mm	150 mm*	180 mm*	75-120 mm
Vergütung Coating	Couche Revestimiento	●	●	●	●	●	●
24x36 cm	40x40 mm						
Länge Length	Longueur Longitud	125 mm	125 mm	125 mm	156 mm	190 mm	148 mm
Front-Ø Front tube Ø	Tube Ø devant Tubo delantero Ø	73 mm	73 mm	73 mm	63 mm	63 mm	61 mm
Gewicht Weight	Poids Peso	174 g	108 g	108 g	206 g	205 g	239 g
Lichtstärke Aperture	Aperture Abertura	f/2.8	f/2.8	f/2.8	f/3.5	f/3.5	f/3.5
Anzahl Linsen Elements	Elements Número de lentes	5	3	3	3	3	7
Bildwinkel Field angle	Champ Angulo de proyección	48°	36°	30°	32°	26°	32°-20°

KODAK RETINAR S-AV 2000 Lenses		26 mm (126.4 ± 0.31)	36 mm (135.4 ± 0.31)	51 mm (150.6 ± 0.51)	70 mm (172.5 ± 0.51)	93 mm (192.8 ± 0.51)	135 mm* (1134.4 ± 0.71)	150 mm* (1149.8 ± 0.71)
Vergütung Coating	Couche Revestimiento	MC	MC	MC	MC	MC	MC	MC
24x36 cm	40x40 mm							
Länge Length	Longueur Longitud	151 mm	125 mm	125 mm	127 mm	125 mm	125 mm	146 mm
Front-Ø Front tube Ø	Tube Ø devant Tubo delantero Ø	73 mm	78 mm	78 mm	78 mm	78 mm	78 mm	73 mm
Gewicht Weight	Poids Peso	721 g	457 g	389 g	386 g	320 g	437 g	605 g
Lichtstärke Aperture	Aperture Abertura	f/2.8	f/2.8	f/2.8	f/2.4	f/2.5	f/2.8	f/2.8
Anzahl Linsen Elements	Elements Número de lentes	9	7	6	5	5	5	5
Bildwinkel Field angle	Champ Angulo de proyección	77°	61°	56°	38,6°	33°	23°	21°

		200 mm** (1200.5 ± 1)	253 mm** (1252.5 ± 1)	45 mm PC (145.2 ± 0.51)	60 mm PC (159.8 ± 0.51)	93 mm PC (193.1 ± 0.51)	85-210 mm** ZOOM
Vergütung Coating	Couche Revestimiento	MC	MC	MC	MC	MC	MC
24x36 cm	40x40 mm						
Länge Length	Longueur Longitud	164 mm	214 mm	142 mm	138 mm	138 mm	176 mm
Front-Ø Front tube Ø	Tube Ø devant Tubo delantero Ø	73 mm	73 mm	72.5 mm	72.5 mm	72.5 mm	68 mm
Gewicht Weight	Poids Peso	618 g	870 g	447 g	359 g	389 g	769 g (1320 g)
Lichtstärke Aperture	Aperture Abertura	f/3.5	f/4	f/2.8	f/2.8	f/2.8	f/3.9
Anzahl Linsen Elements	Elements Número de lentes	5	5	6	6	5	15
Bildwinkel Field angle	Champ Angulo de proyección	16°	13°	50°	39°	26°	27°-12°

* Für die Projektion von 40x40 mm Dias empfehlen wir den Spezialkondensator (CAT 706 0833) einzusetzen.
 ** Spezialkondensator grundsätzlich notwendig (liegt dem Objektiv bei).

* For projection of 40x40 mm slides the use of the special condenser lens (CAT 706 0833) is recommended.
 ** Use of the special condenser lens necessary and enclosed with the lens.

* Pour la projection de dispositifs 40x40 mm il est recommandé d'utiliser un condensateur KODAK CAROUSEL (CAT 706 0833).
 ** Il est nécessaire d'utiliser le condensateur fourni avec l'objectif.

* Para la proyección de diapositivas de 40x40 mm se recomienda el uso de la lente condensadora especial (No. CAT 706 0833).
 ** Es necesario el uso de la lente condensadora especial que se incluye con el objetivo.

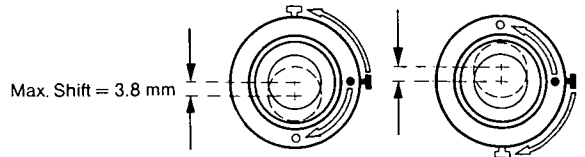
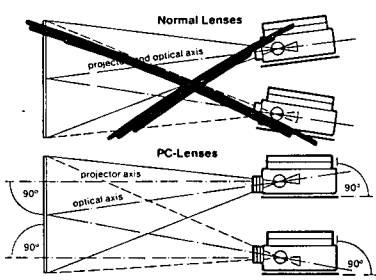
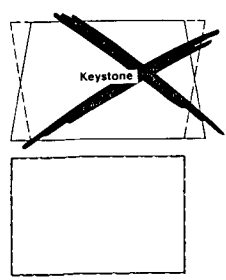

M

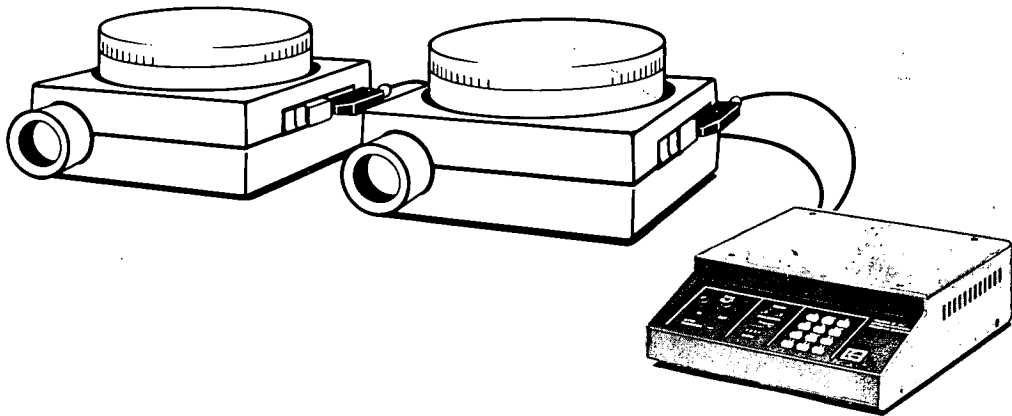

KODAK S-AV
Programmable Dissolve Control

N O

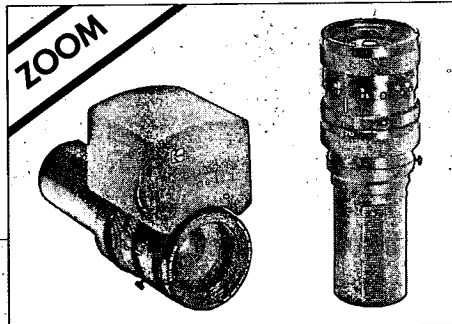

KODAK VARIO-RETINAR
S-AV 2000 Zoom Lenses 85-210 mm

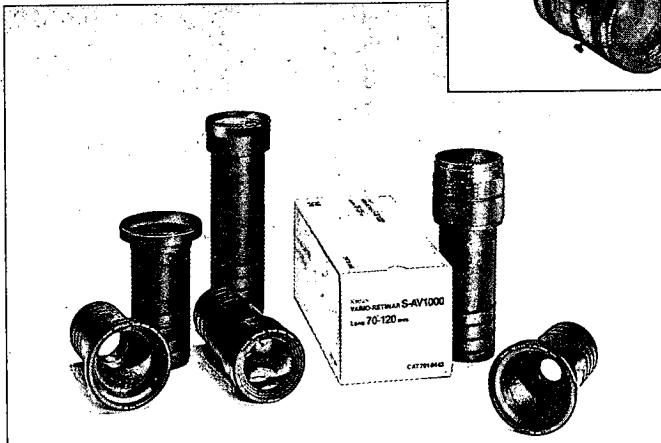

KODAK RETINAR S-AV1000 Lenses

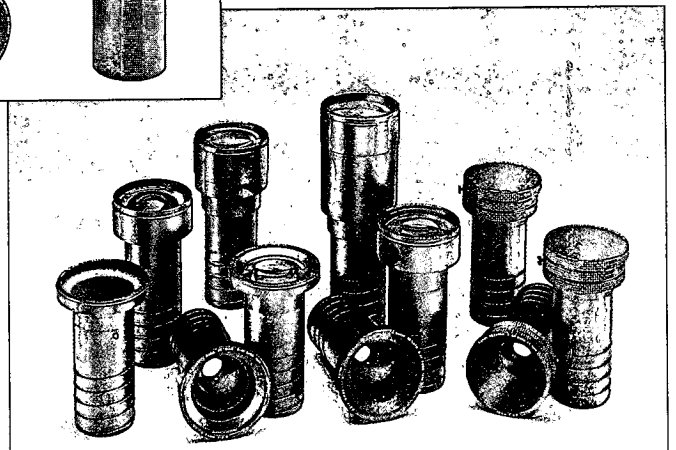

KODAK RETINAR S-AV 2000 Lenses

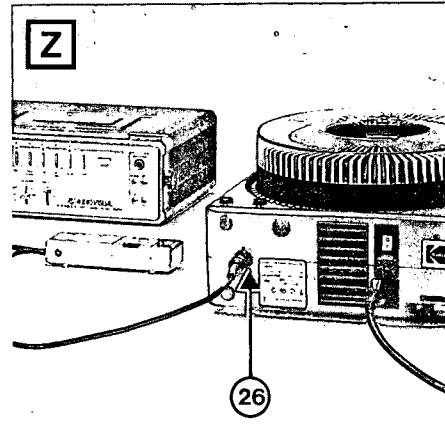
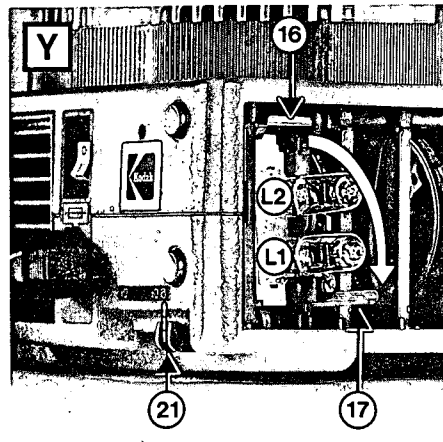
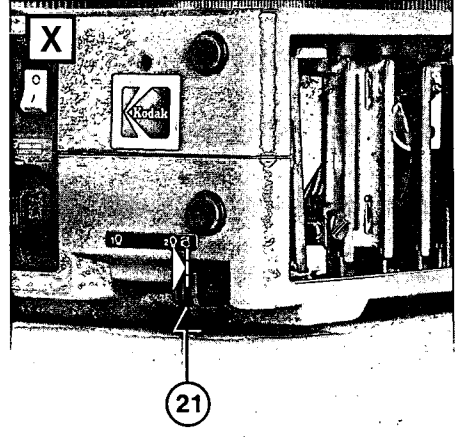
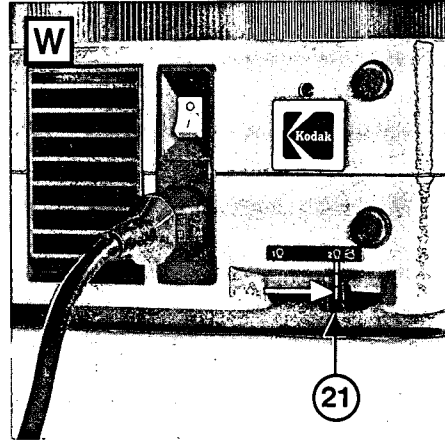
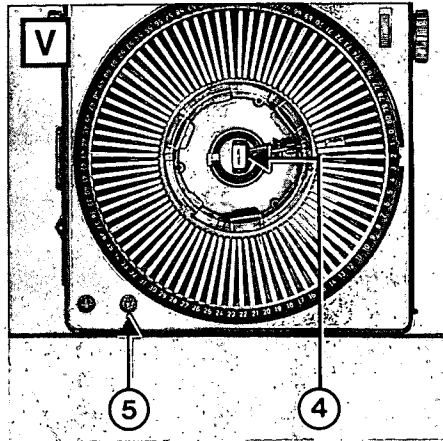
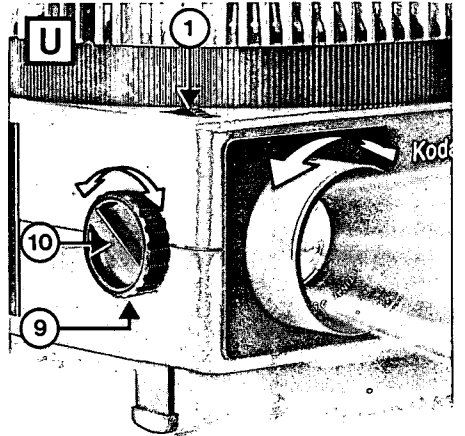
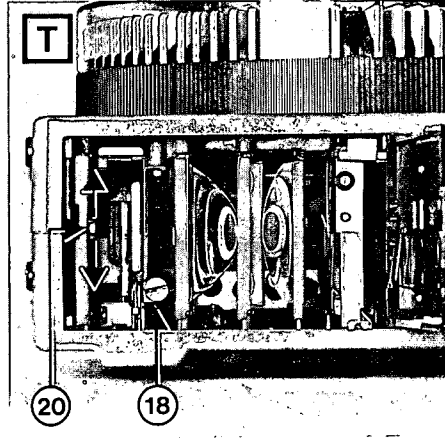
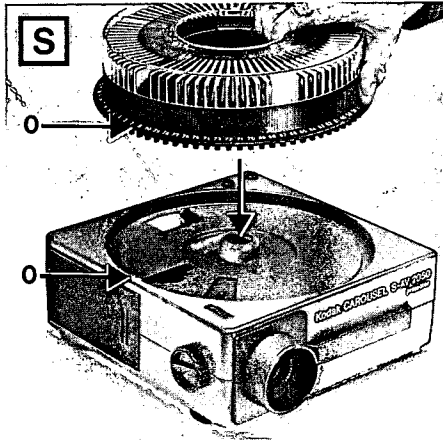
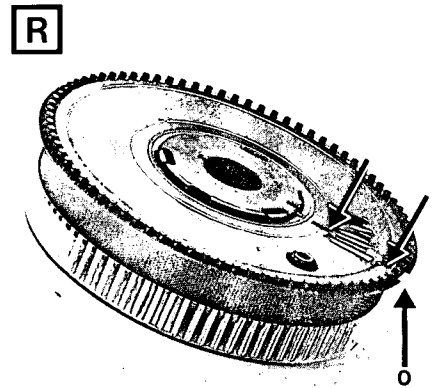
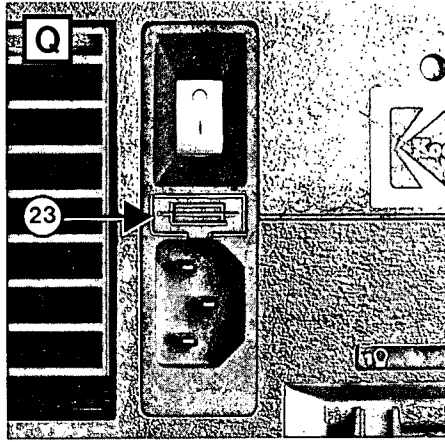

Projectionsbildbreiten
Projected picture sizes
Dimensions des vues projetées
Anchura de la imagen proyectada

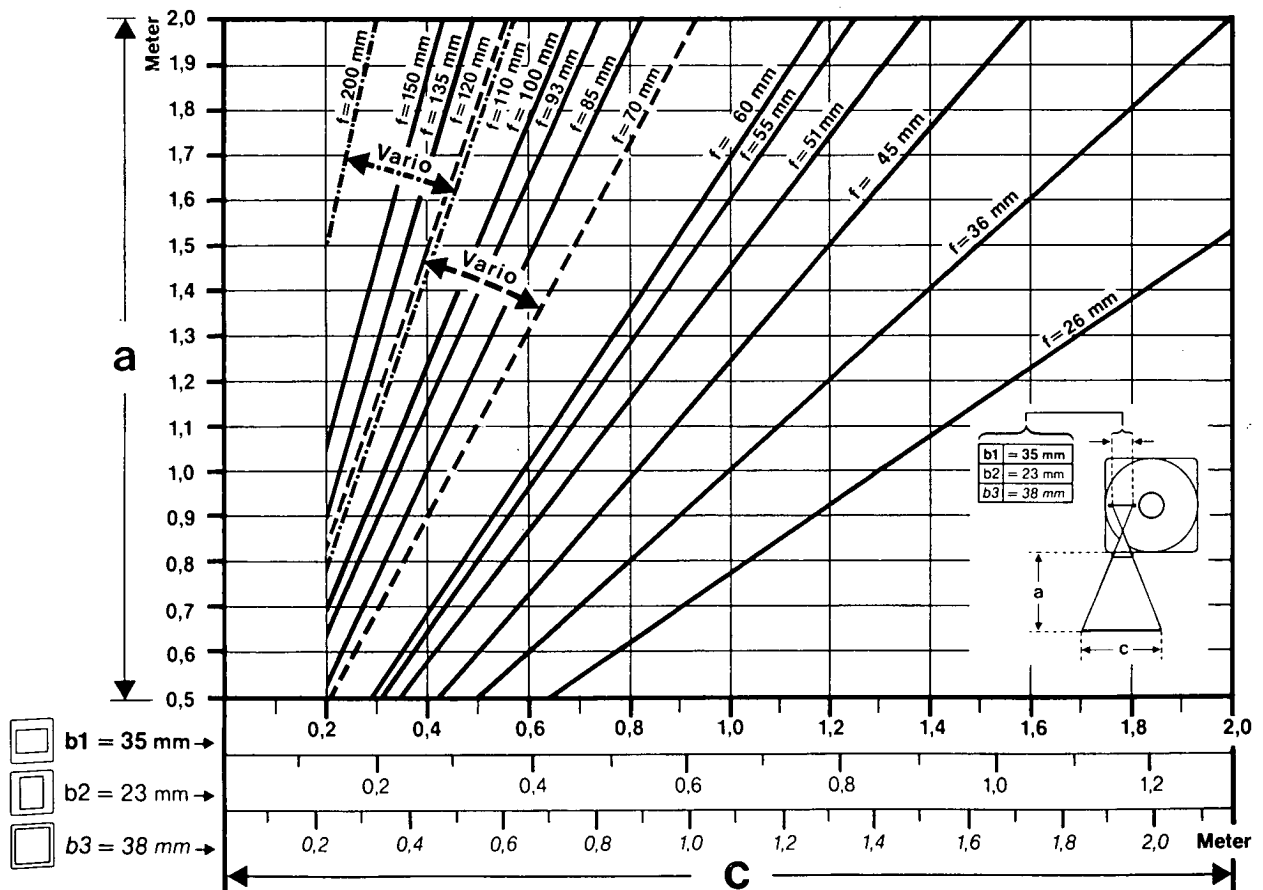
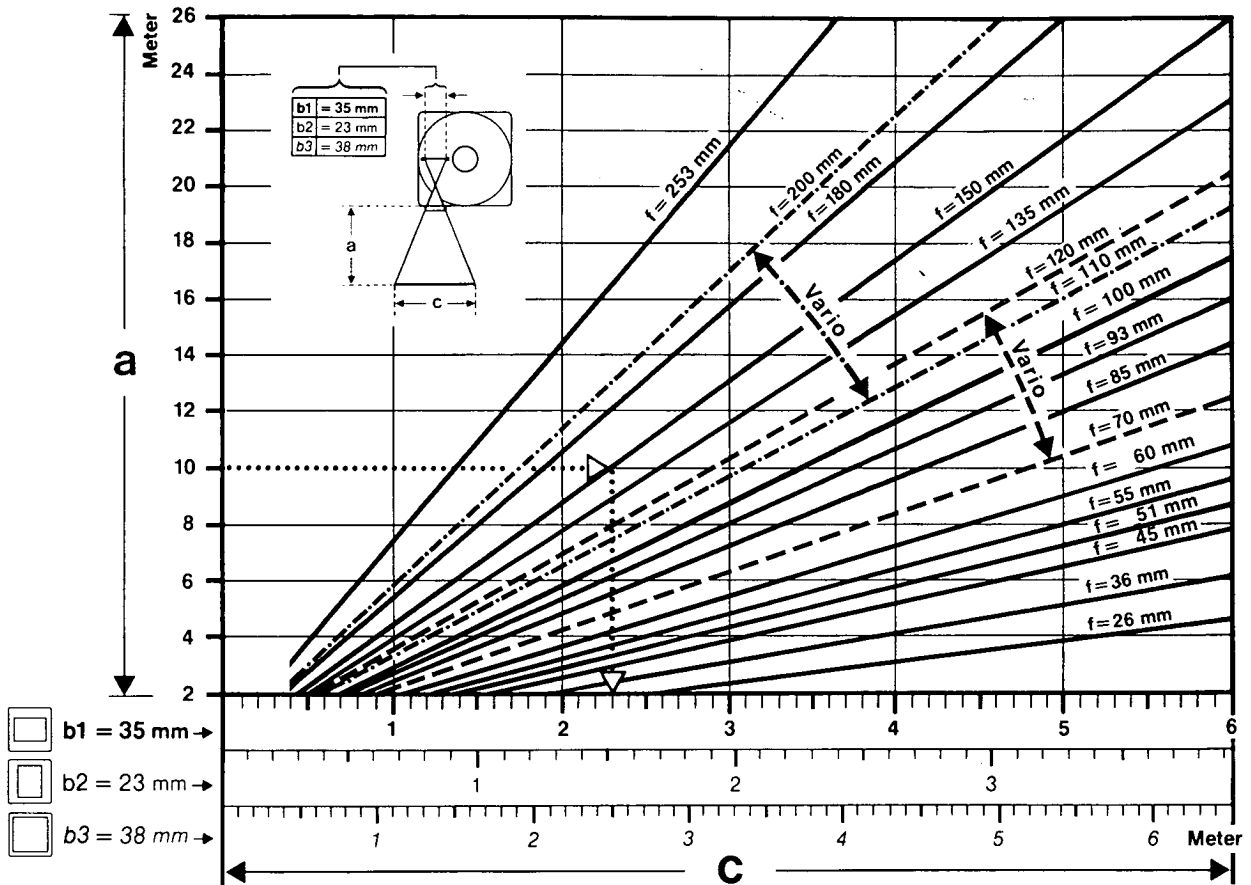
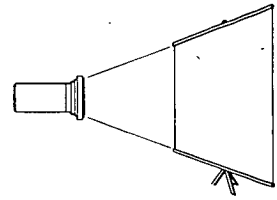



Example of projector cones for at 1m or 6m throw onto 1m wide target using Kodak S.A.V

Projectors should be kept horizontal
PC Allows the image to shifted up or down on the wall by @5% without distortion,
THIS GUIDE IS FOR ILLUSTRATIVE PURPOSES, WE RECOMMEND TESTING YOUR SET UP BEFORE FIXING ANYTHING DOWN

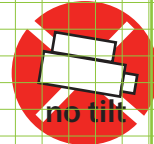

ground floor 7.35m wide

lower ground floor 4.8m wide

110-200mm zoom

70-120mm PC zoom

60mm PC

50mm

45mm PC

25mm

H&S recommended overhead clearance for rigged items 2.4m

average head height 1.75m

offset for PC "Lens shift"

Kodak dims

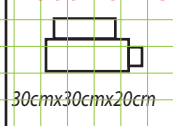

Projectors can be
Wall mounted on a 40cm x40cm shelf
Plinth mounted on a 35x35mm (PLUS) weighted plinth 1m-1.8m high
Suspended in an Insight hanging cradle (subject to head height clearance and keystone correction)

1m

grid scale metre squares div 10cm

Distance to screen from lens in metres

